



FreshStream

Reverse Osmosis Undersink
Water Filtration System

Owners Installation Manual

Models:

CPK - FRESHSTREAM4

CPK - FRESHSTREAM5

The Kenai FreshStream RO system is made with quality components to provide to provide cleaner, safer drinking water. No chemicals are added or used in this system.

This manual is applicable to Product Models:

CPK - FRESHSTREAM4

CPK - FRESHSTREAM5

Table of Contents

i.	Notice	
ii.	Parts List	
1.0	Introduction	pg. 1
2.0	Installation	pg. 2
2.1	Location of RO Unit	pg. 2
2.2	Mounting the RO filter Unit Under a Sink	pg. 3
2.3	Connecting the Feed Water Supply	pg. 4
2.4	Installation of non UPC Drain Connection	pg. 5
2.5	Installation of Clean Water Faucet	pg. 5
2.6	Porcelain/Enamel Over Steel or Cast Iron Sinks	pg. 6
2.7	Install Faucet	pg. 7
2.8	Tubing Connections	pg. 8
2.9	Air Gap Faucet Installation	pg.10
3.0	System Start Up	pg. 11
3.1	Air Purge	pg. 11
3.2	Start-Up	pg. 11
4.0	Recommended Filter Changes	pg. 12
4.1	Filter Replacement for 5-stage FreshStream	pg. 12
4.2	Filter Replacement for 4-stage FreshStream	pg. 12
5.0	Filter Replacement Procedure	pg. 13
6.0	Conditions of Use	pg. 13
7.0	Installation Troubleshooting	pg. 13
8.0	Two-Year Limited Warranty	pg. 14
9.0	Performance Data Sheet	pg. 15
9.1	Arsenic Facts	pg. 16
	Appendix A: Theory of Operation	pg. 17
A.1	Pre Filters	pg. 17
A.2	The Reverse Osmosis Membrane	pg. 17
A.3	Auto Control	pg. 18

i NOTICE

This instruction manual was written to guide a professional plumber to make an easy installation of the Kenai FreshStream. The installation shall conform to state and local laws and regulations.

This manual covers the FRESHSTREAM4 AND FRESHSTREAM5 systems with 50 gallon per day membranes.

This filter system can be installed by the homeowner who has sufficient tools and skills. Be cautioned that an extra faucet for purified water will be installed . This requires a 7/8-inch diameter hole in the sink top. If there is not an extra hole existing, a new one must be drilled. For a porcelain sink, this requires a special drill (7/8" Relton cutter) which costs about \$200 and requires skill to use.

ii PARTS LIST

Parts contained in the Kenai FreshStream carton:

- 1-Box containing storage tank
- 1-Box with filter assembly
- 1-Set of orange, white and black plastic tubes
- 1-clean water faucet and fittings
- 1-set of installation hardware

1.0 INTRODUCTION

The Kenai FreshStream is a 4 or 5-stage water cleansing system. The 5-stage system is identical to the 4-stage; with an additional carbon prefilter. For simplicity, this manual will be referencing the 5-stage system. The principle cleansing of the water of its dissolved solids is performed by the Reverse Osmosis membrane filter (Stage 4).

Stage One is a sediment filter that removes particles 5-microns in size or larger including rust, sand and other debris in the water line.

Stage Two and Three are granular activated carbon (GAC) filters that remove odors, chlorine and foreign tastes.

Stage Four is an advanced Reverse Osmosis membrane for removal of dissolved solids. This is the heart of the system. Reverse osmosis technology removes 95% of the dissolved solids on average. Dissolved solids are not removed by municipal water treatment, That is why the Kenai FreshStream is an important safety factor for the water you drink and use in your cooking. Chemical contaminants such as mercury, lead and others not yet identified that seep into municipal water systems are removed.

The water pressure forces the water molecules through the Reverse Osmosis membrane, but the larger contaminant molecules do not pass through the membrane and are flushed to the drain. The clean water goes to the storage tank and is held there ready to use.

Stage Five (post-filter) is a Carbon polishing filter that removes any foreign tastes or odors that may occur from storing the water. The storage tank is pre-pressurized with a bladder that pushes the water through Stage Five to the faucet. When the faucet is opened, clean water from the storage tank flows through this final polishing filter of activated carbon and into the faucet for your use.

A special faucet is installed on your sink which dispenses safe, great tasting drinking water, which is especially good for making coffee, tea and drinks. By extending a line to your refrigerator, this water can also be used to make ice cubes.

Filter Life Span

Kenai recommends changing the pre and post filters once every year, and the reverse osmosis membrane every 3 years.

2.0 INSTALLATION

Before starting the installation, you should measure the water pressure that is available under the sink to power the FreshStream RO. If the pressure is less than 40-psig, it is too low; and if it is 90-psig, it may be too high. The solution if the pressure is too low is to use a model with a booster pump. The solution for high water pressure, is to put a pressure regulator in the inlet water line to the house. A pressure of 60-75 psig is normal.

2.1 Location of RO unit

The RO unit may be located under the kitchen sink or in the basement. A cold water supply line must be close by. When locating the system under a sink make sure there is adequate room for the filter module assembly as well as the storage tank. For best performance the tank should be located as close to the clean water faucet (supplied) as possible (within 20 feet).

2.2 Mounting the RO filter unit under a sink (Fig. 1.)

Mount the unit to the wall of the sink cabinet. Pre-fit the unit by positioning the bottom of the pre-filter cartridges 2 inches off the floor of the cabinet. This clearance is necessary to make room to remove the housings when replacing the filter cartridges. Mark the location of the 2 mounting holes in the mounting bracket. Install 2 mounting screws leaving 1/8 inch clearance under the screw head. Check the fit by mounting the RO filter unit but don't install yet.

A 1/4" ball valve is supplied so the homeowner can easily shut off feed water when leaving the home unattended. The best overall protection from potential water leaks in the kitchen, hot water heater, or utility room is to install an automatic leak detector shutoff valve to the house.

Figure 1

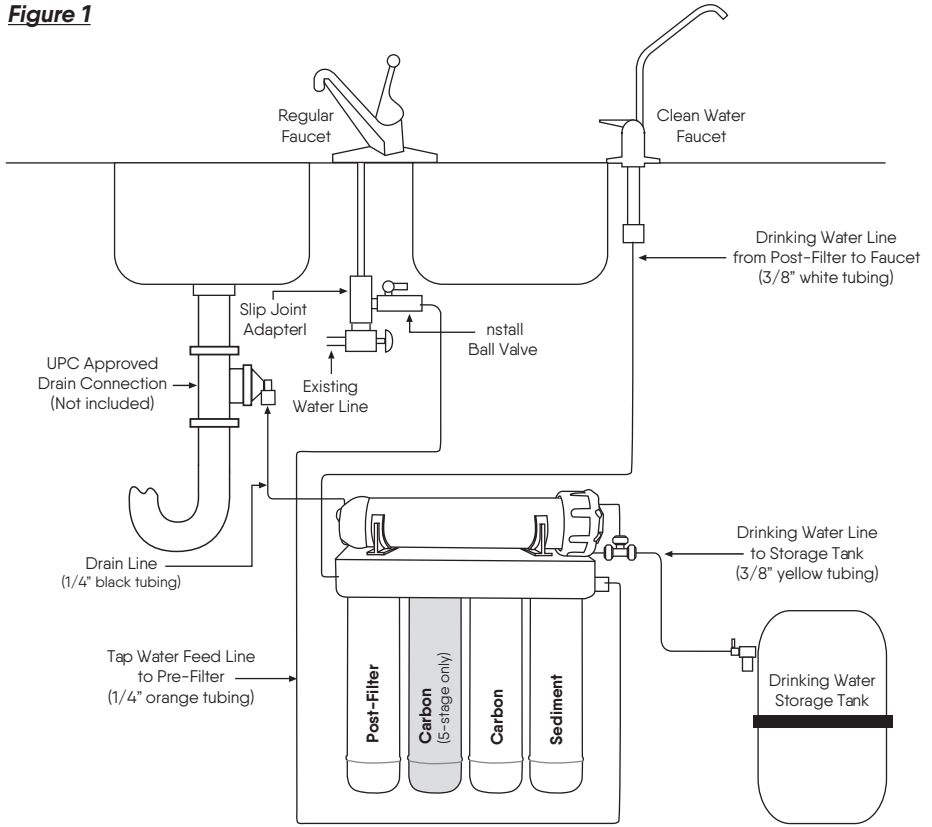

Figure 2 RO SYSTEM TOP VIEW

Feed Water Line

Orange Tubing from Pre-Filters

Pure Water Line

White tubing

Drain Water Line

Black Tubing to Drain

To Clean Water Tank

Auto-Valve
(rotated 90° for clarity)

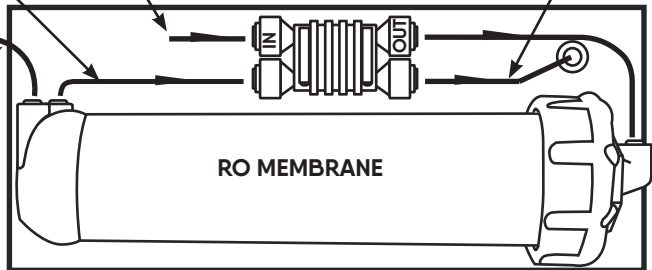

2.3 Connecting the feed water supply (Figure 3)

The feed water assembly consists of 1/2" brass slip joint adapter, a black washer, and a 1/4" x 1/4" ball valve. Locate these parts in the installation kit.

Locate the cold water shut off valve under the sink and turn it off. Open the cold water faucet to release the pressure. On single handled faucets, the hot water may have to be turned off to prevent any hot water cross-over. If water continues to come out of the faucet with the under-sink valves turned off, the house main valve will have to be turned off.

With the water turned off, disconnect the cold water riser tube (flex line) from the valve. Install the slip joint connector with the black washer. Loosen the nut and separate the cold riser tube from the faucet shank. Gently bend the riser tube so that the slip joint adapter fits onto the faucet shank. Reinstall the cold riser tube on the slip joint connector using the existing cone washer. For Solid copper tube the procedure is the same except you must cut a piece of the riser tube about 3/4" to 1" so the slip joint adapter can fit between the valve and the riser tube. Wrap several turns of Teflon tape on the ball valve and install on the slip joint connector.

Figure 3

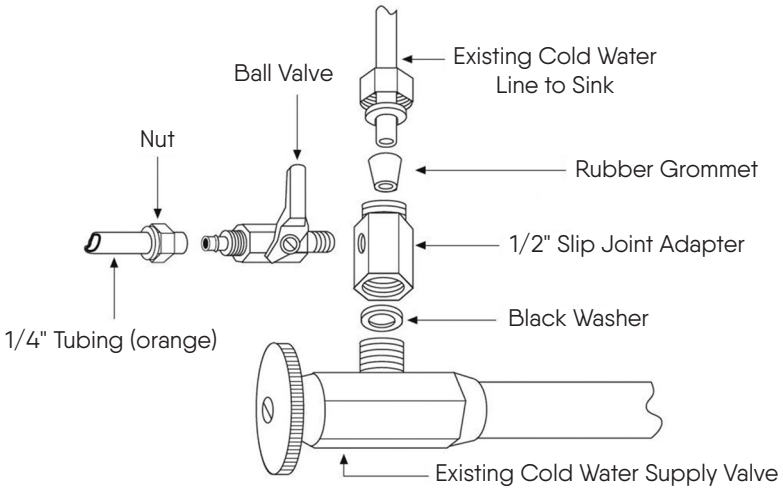

2.4 Installation of Non-UPC drain connection (Figure 4)

Place the drain outlet saddle on the drain pipe. Allow proper space for the drilling operation. Tighten the saddle bolts evenly on both sides. Using the opening in the drain outlet saddle as a guide, drill a 1/4" hole in the drain pipe. Clean any debris out of the drain saddle connection.

Figure 4

Alternate drain connection where UPC is not required

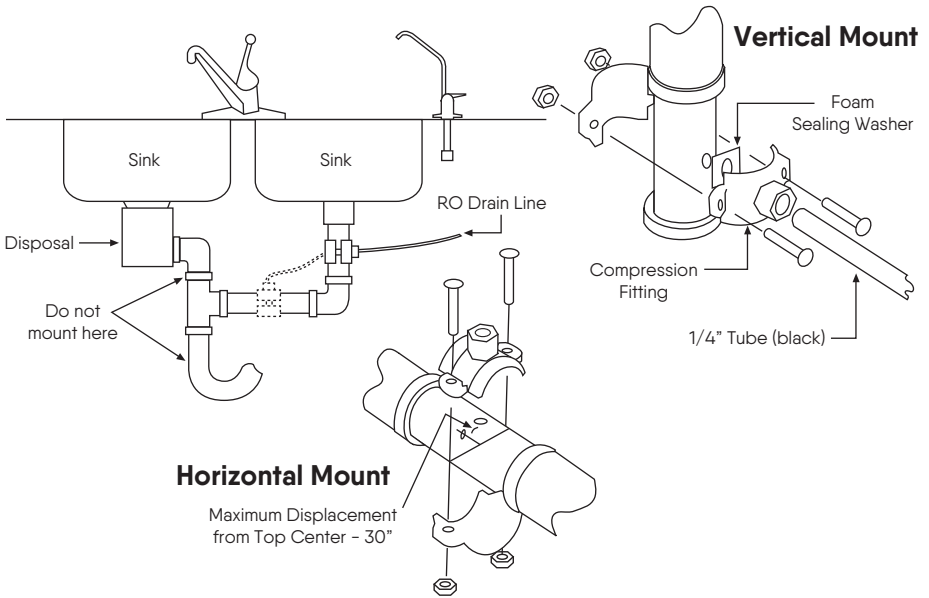

2.5 Installation of clean water faucet

The faucet should be positioned with aesthetics, function, and convenience in mind. An ample flat area is required for the faucet base so that it can be drawn down tight. The space under the sink below where the faucet will be mounted must be clear of any obstructions.

Some conditions may eliminate the need to drill a hole in the sink such as a faucet previously installed in the sink, a hole covered by a chrome hole cover, or an unused spray handle. If any of these situations are present, you may mount the faucet in one of these holes.

The sink drilling process is not complicated, but requires a certain amount of caution and forethought. Porcelain sinks can be chipped if care is not exercised when drilling the hole for the faucet.

2.6 Porcelain/Enamel over Steel or Cast Iron Sinks

Using a small diameter carbide tipped drill, drill a pilot hole completely through the porcelain and the material underneath. Remove any metal chips that fall into the sink to prevent rust stains. Place the spring-loaded porcelain cutter bit in to the drill chuck. Make sure the pilot guide is inserted tightly. Insert the pilot guide onto the pilot hole. Push down gently on the drill motor to apply light pressure to the porcelain surface. Start the drill motor, turning as slowly as possible. After the initial cut has started, motor speed may be gradually increased. The cut may require three to four minutes to complete. Going faster could result in excessive chipping. Be sure a complete ring has been cut through the porcelain to the metal underneath.

Place the finish hole saw into the drill chuck. Make sure the pilot guide is inserted tightly. Insert the pilot guide into the pilot hole. Begin cut using a slow speed and light pressure until the porcelain has been penetrated to the material underneath. Remove the saw from the hole and clean all debris from the porcelain surface. Reinsert saw into the hole and cut through the remaining material.

[NOTE: This procedure is for the non air gap faucet provided.]

Figure 5

Step 1.

Pilot Drill

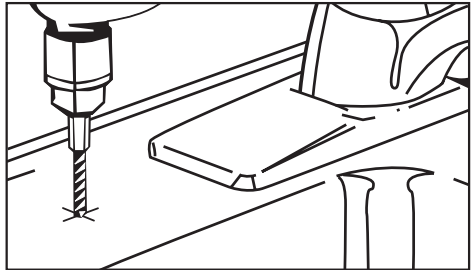

Step 2.

Spring loaded
porcelain saw
(Relton cutter)

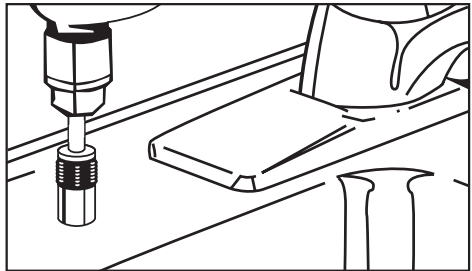
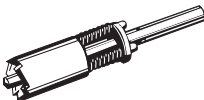

Step 3.

Finish hole saw

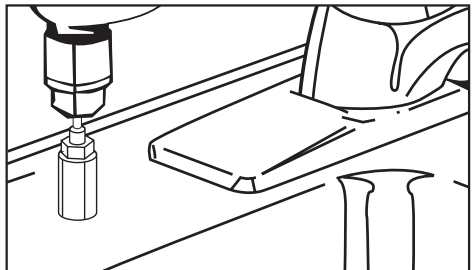
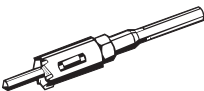

2.7 Install Faucet (Figure 6)

Disassemble the hardware from the threaded stud except for the top base plate and sealing gasket. Install the faucet in the sink hole. From below the sink assemble the mounting hardware. Use a deep socket to tighten the nut.

Figure 6

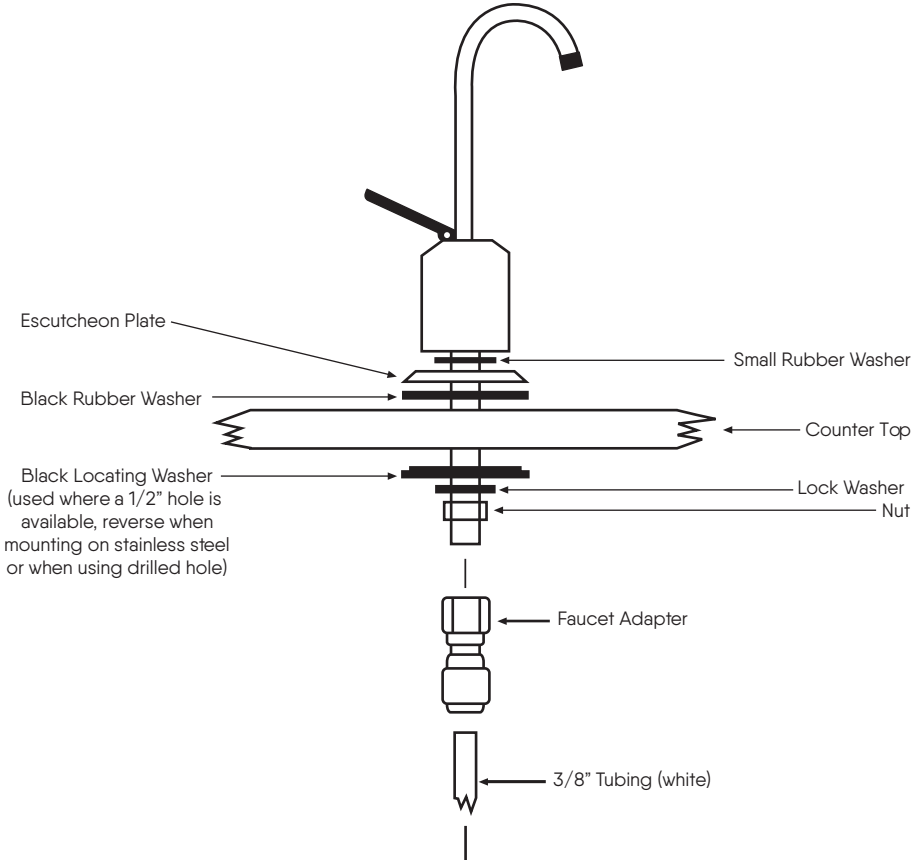

2.8 Tubing Connections (Figure 7)

- a. The standard tubing connections on the **Kenai FreshStream** are of Quick Connect O-ring seal design and manufacture. Use the tubing and follow the instructions in Figure 8 to make the connections. If you cut the tubing, make sure it is a square cut and that the tubing fits evenly in the fitting and seals properly.

1 Cut tube square

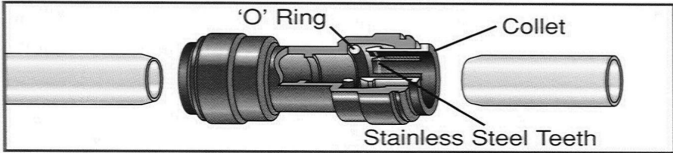

Cut the tube square. It is essential that the outside diameter be free of score marks and that burrs and sharp edges be removed before inserting into fitting.

2 Insert tube

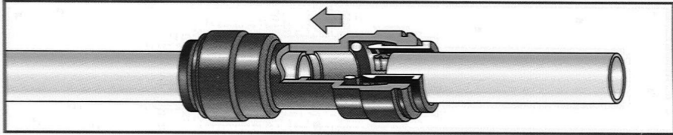

Fitting grips before it seals. Ensure tube is pushed in to the tube stop.

3 Push up to tube stop

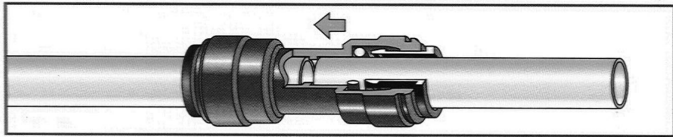

Push the tube into the fitting, to the tube stop. The collet (gripper) has stainless steel teeth which hold the tube firmly in position while the 'O' ring provides a permanent leak proof seal.

4 Pull to check secure

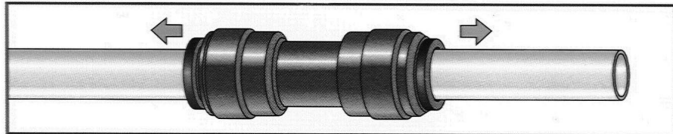

Pull on the tube to check it is secure. It is good practice to test the system prior to leaving site and/or before use.

Disconnecting

Push in collet and remove tube

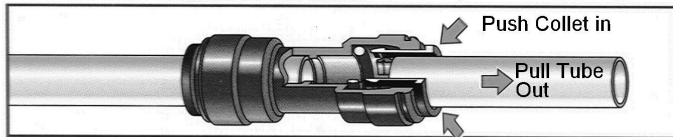

To disconnect ensure the system is depressurized before removing fitting. Push in collet squarely against face of fitting. With the collet held in this position, the tube can be removed. The fitting can then be re-used.

Figure 7

b. Feed Water Line

Connect the orange colored 1/4" inlet tubing to the ball valve, or saddle valve installed in Step 2.3 above. To reduce the water hammer effect on this fitting, make a large loop in the tubing before the connection on the sediment filter. To connect, remove compression nut insert tube over the ball valve tube as shown in Figure 3. Slide nut over threads and tighten. Connect the other end of the tube to the inlet fitting using the method as described in Section 2.8

c. Drain Line

Find the black colored 1/4" tubing. Connect the tube to the drain saddle clamp from Step 2.4. Push the tube into the fitting about 1/2 inch. Tighten plastic nut.

d. Faucet Line

Screw the faucet adapter on to the end of the faucet. Find the white colored 3/8" tubing and insert into the quick connect fitting as described in Section 2.8a. Connect the end of the tube to the quick connect fitting on the post filter (stage 5). Push the tube into the fitting until it stops.

e. Tank Line

Install the plastic ball valve on the storage tank. Find the yellow-colored 3/8" tubing and connect the tube to the plastic ball valve on the tank. Push tube into fitting until it stops. Connect the other end of the yellow tube to the "T" fitting. The tank comes pre-charged from the factory at 5-7 psi. Double check the pressure with a tire gage (the air fitting is on the opposite end of the tank from the ball valve). If it is less than 5 psi add 2 psi with a compressor or bicycle pump.

Note: Putting more pressure than 7 psi does not help to increase water flow through the faucet.

Figure 8

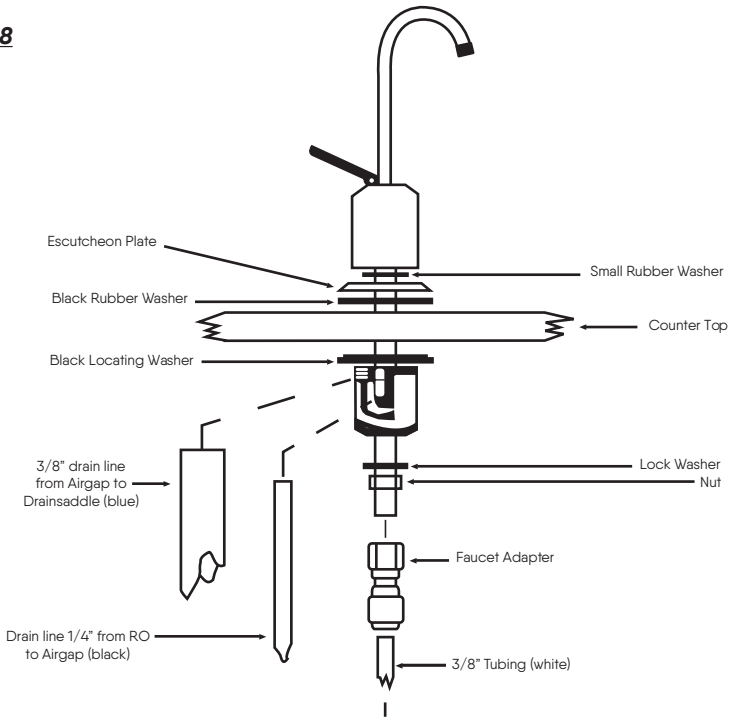

2.9 Air-Gap Faucet Installation (Figure 8)

Air-Gap Faucets are sometimes required by municipal code. The faucet is designed to take the waste water from the membrane to the top of the sink and then let it flow by gravity to the drain saddle. The objective is to prevent possible backup of drain water from the sink to the membrane in the event of a sink clog. A drain saddle with 3/8" instead of 1/4" is used. An extra section of 3/8" tubing (black) is used from the faucet to the drain.

Sink Preparation

Drill the appropriate size hole in the kitchen sink to accommodate the air-gap faucet.

Drain Connection

Follow instructions of section 2.5 except drill a 3/8" hole in the drain pipe.

Tubing Connections

Find the black colored 1/4" drain line from the membrane. Connect this tube to the 1/4" barbed fitting on the air-gap faucet.

Find the 3/8" black tubing in the parts kit. Connect this tube to the 3/8" barbed fitting on the air-gap faucet. Install the faucet assembly (with tubes attached) into the sink hole. Secure the faucet per instructions in section 2.8. Re-attach the 1/4" black tubing to the drain side of the RO membrane housing. Attach the 3/8" tube to the drain connector. Tighten the fitting nut securely. Attach the pure water line to the faucet per the instructions in section 2.9-D.

Note: To reduce drain noise gently curve the black tubing from the air-gap faucet to the drain connection.

3.0 System Start-Up

3.1 Air Purge

The filter elements of stage 1, 2, 3, and 5 filters as shipped are dry and contain air in the pores. The air will slowly be expelled but may collect in the system and will need to be purged for peak operating efficiency. Proceed with Section 3.2 for air purge and initial start-up procedure.

3.2 Start-Up

Start the system by opening the feed water ball valve. Make sure the ball valve on the storage tank is in the closed position. Check for leaks for at least 10 minutes. Open the product water faucet and let the water flow until all the air has been expelled from the system. This will take about 30 minutes.

Close the product water faucet. Now open the tank valve. Let the system run for about 2-hours to fill the storage tank. Then open the clean water faucet on the sink and empty the tank. Dump and fill for a total of four times. This is to flush the tank and remove the preservative from the RO membrane, as well as carbon "fines" from the post filter that may have collected in the tank .

If the waste continues to run after the tank is full, it may mean there is air binding the autovalve. Empty the tank again by opening the faucet. This will help to clear more air from the system.

4.0 Recommended Filter Changes

4.1 Filter Replacement, Kenai FreshStream 5-Stage

Filter element replacements of Stage 1, 2, 3, and 5 are mandatory once a year to maintain water purity.

To maintain the Platinum Seal Certification, only these replacement parts should be used.

The recommended replacement frequency is listed below:

		Replacement Frequency
Sediment Filter Element, Stage 1	TF-4113	6-12 Months
Pre-Carbon GAC Element, Stage 2	TF-4114	6-12 Months
Pre-Carbon Filter Element, Stage 3	TF-4115	6-12 Months
RO Membrane Assembly, Stage 4	MHA-4222	3-5 Years
Post Carbon Filter Element, Stage 5	TF-4115	6-12 Months

These filter replacement elements and kits are available from your DEALER. If not available, contact Kenai for dealer information.

Kenai, 8150 N. Lehigh Ave, Morton Grove, IL 60053
Text: 847-466-4378 email: kenai@chargerwater.com

4.2 Filter Replacement, Kenai FreshStream 4-stage

Filter element replacements of Stage 1, 2 and 4 are mandatory once a year to maintain water purity.

To maintain the Platinum Seal Certification, only these replacement parts should be used. The recommended replacement frequency is listed below:

		Replacement Frequency
Sediment Filter Element, Stage 1	TF-4113	6-12 Months
Pre-Carbon Filter Element, Stage 2	TF-4115	6-12 Months
RO Membrane Assembly, Stage 3	MHA-4222	3-5 Years
Post Carbon Filter Element, Stage 4	TF-4115	6-12 Months

These filter replacement elements are available from your dealer. When you buy or install your **Kenai FreshStream**, we recommend that you buy the first year filter replacement kit.

This kit comes in a plastic bag which can be attached to the installed **Kenai FreshStream** under your sink. There is a space to write in the date of replacement, which is a maximum of a year from the date of installation. In the replacement kit are instructions for replacement and cleaning.

At year 3 (or sooner if you have severe water problems), we recommend that the reverse osmosis assembly be changed also. When you order your third year kit from your Kenai dealer, request the RO membrane assembly along with the other filters.

5.0 Filter Replacement Procedure

The standard tubing connections on the Kenai FreshStream are of Quick Connect O-ring seal design and manufacture. Use the tubing and follow the instructions in Figure 8 to make the connections. If you cut the tubing, make sure it is a square cut and that the tubing fits evenly in the fitting and seals properly. Turn off the feed water at the feed water ball valve. Turn the storage tank ball valve to the off position and open the faucet. This will depressurize the system. Put a shallow pan under the RO system to catch any water that may spill during the operation.

Unscrew filter body (1/4 turn counter clockwise), pull down, and carefully lift it to the sink to drain the remaining water. Discard spent filter body. To install new filter body remove red cap from cartridge, lubricate both o-rings on filter stem using common cooking oil or Vaseline then insert it into the head and turn 1/4 turn clockwise. Repeat operation for all 3 pre-filters (for 4-stage system, only 2 pre-filters) and one post-filter.

6.0 Conditions Of Use

Water must be microbiologically safe. System pressure, 40 to 100 PSIG. Temperature, 40 to 100°F. pH range, 3 to 10. Maximum TDS, 1500 PPM. Maximum Iron (FE) 0.3ppm, Maximum Manganese (Mn) .01ppm, Turbidity, less than 1.0 NTU.

7.0 Installation Troubleshooting

<u>Problem</u>	<u>Possible Cause</u>	<u>Solution</u>
<ul style="list-style-type: none"> • No or low water production. 	<ul style="list-style-type: none"> • Feed water shut off. • Tank valve closed or partially closed. • Low feed pressure. Feed pressure must be at least 40 psi. 	<ul style="list-style-type: none"> • Turn on feed water. • Open tank valve. • Increase inlet water pressure or install booster pump if feed water pressure is less than 40 psi.
<ul style="list-style-type: none"> • Leak at filter housing. 	<ul style="list-style-type: none"> • Defective or misaligned O-ring. 	<ul style="list-style-type: none"> • Shut off feed valve and tank valve. Turn on faucet. Change or realign O-ring.
<ul style="list-style-type: none"> • Leak at tube connection. 	<ul style="list-style-type: none"> • Not properly installed. 	<ul style="list-style-type: none"> • Tighten compression fitting • Remove tube and re-install into fitting.
<ul style="list-style-type: none"> • Bad-tasting water. 	<ul style="list-style-type: none"> • Post-filter cartridge not flushed completely. 	<ul style="list-style-type: none"> • Flush one or two tanks of pure water through system.
<ul style="list-style-type: none"> • Water runs to drain all the time. 	<ul style="list-style-type: none"> • Auto-valve not closing properly. • Check valve not functioning properly 	<ul style="list-style-type: none"> • Purge the system again. • Clean or replace check valve
<ul style="list-style-type: none"> • RO Production good at first but falls off in months or weeks. 	<ul style="list-style-type: none"> • High TDS and/or Iron and Manganese. 	<ul style="list-style-type: none"> • Consult your dealer or Factory and provide water analysis.

8.0 Two-Year Limited Warranty

Kenai sells its products through independent water dealers who re-sell the product to the end user.

Kenai warrants the FreshStream RO system to be free from defects in materials and workmanship for a period of TWO YEARS from date of purchase. This warranty does not cover damage resulting from accident, mis-use, neglect, improper installation, or subjection to water pressure in excess of 100 lbs. per square inch. The warranty shall extend only to the original purchaser of the product from a Kenai dealer for use by the purchaser. Any modifications of the product shall render the warranty invalid and Kenai will have no further responsibility. All warranty claims must be made to the Kenai dealer from which the product was purchased.

Kenai shall in no event be liable for any incidental or consequential damages of any kind; the sole obligation of Kenai being limited to repair or replacement of defective parts of product. Proof of purchase, date of purchase, and name of dealer are required.

Any implied warranties herein are limited in duration to a period of two years from the date of original purchase or the shortest period allowed by law.

9.0 Performance Data Sheet

Models:
CPK - FRESHSTREAM4
CPK - FRESHSTREAM5

Contaminant Reduction Typical RO

Substance	Influent Challenge Concentration mg/L	Max permissible product water concentration mg/L	Minimum Percent (%) Reduction	Average Percent (%) Reduction
Arsenic (+5)	0.30 ± 10%	0.010	98.1	99.0
Barium	10.0 ± 10%	2.0	95.0	98.8
Cadmium	0.03 ± 10%	0.005	94.0	98.3
Chromium (+6)	0.3 ± 10%	0.1	95.5	98.3
Chromium (+3)	0.3 ± 10%	0.1	98.4	99.0
Copper	3.0 ± 10%	1.3	95.0	98.4
Fluoride	8.0 ± 10%	1.5	87.0	93.8
Lead	0.15 ± 10%	0.010	90.4	96.8
Radium (226/228)	25 pCi/L	5 pCi/L	80.0	80.0
Selenium	0.10 ± 10%	0.05	94.4	97.9
TDS	750 ± 10%	187	88.0	92.2
Turbidity	11 ± 1 NTU	0.5 NTU	96.4	98.7

This system can typically treat water containing pentavalent arsenic (also known as As(V), As(+5), or arsenate) at concentrations of 0.30 mg/L or less. This system reduces pentavalent arsenic, but may not remove other forms of arsenic. This system is to be used on water supplies containing a detectable free chlorine residual or on water supplies that have been demonstrated to contain only pentavalent arsenic. Treatment with chloramines (combined chlorine) is not sufficient to ensure complete conversion of trivalent arsenic to pentavalent arsenic. Please see the Arsenic Facts section of the Performance Data Sheet for further information.

Conforms to NSF/ANSI 58 for pentavalent arsenic reduction. See 9.1 arsenic facts section for an explanation of reduction performance. Testing performed under standard laboratory conditions. Actual performance may vary.

Specifications

75 gallon per day reverse osmosis membrane
 Storage tank: 4.0 gallon total volume; 2.2 gallon water volume
 Dimensions: 14in. long by 6in. wide by 15.5in. high; Tank: 11in. dia by 15 1/2in. high Weight: 24 pounds

Conditions of Use

Do not use with water that is microbiologically unsafe, or of unknown quality, without adequate disinfection before or after the system.
 Pressure: Minimum-40psig; Maximum-100psig
 Temperature: 40 to 100°F
 pH Range = 3.0 to 10, max iron content - 0.3ppm
 Turbidity of inlet water-less than 1.0 NTU, maximum TDS-1500ppm

This system contains replaceable treatment components critical to effective reduction of TDS and efficiency of the system. Replacement of the reverse osmosis component should be with one of identical specifications, as defined by the manufacturer, to ensure the same efficiency and contaminant reduction performance. Replacement parts and numbers are shown below. The product water should be tested periodically to verify that the system is performing satisfactorily in addition to making the parts replacement specified.

Recommended Changeout Interval

RO Membrane Assembly 50gpd, P/N MHA-4222	once each 3 years
First stage sediment filter, 5-micron, P/N TF-4113	once each year
Second stage (5-stage only) granular activated carbon, P/N TF-4114	once each year
Second stage activated carbon block, P/N TF-4115	once each year
Post filter, activated carbon block, P/N TF-4115	once each year

See OWNER INSTALLATION manual for complete installation/operation and maintenance requirements, including manufacturer's limited warranty.

9.1 Arsenic Facts

Arsenic (abbreviated As) is found naturally in some well water. Arsenic in water has no color, taste, or odor. It must be measured by a laboratory test. Public water utilities must have their water tested for arsenic. You can get the results from your water utility. If you have your own well, you can have the water tested. The local health department or state environmental health agency can provide a list of certified labs. The cost is typically \$15 to \$30. Information about arsenic in water can be found on the internet at the U.S. Environmental Protection Agency website: www.epa.gov/safewater/arsenic.html.

There are two forms of arsenic: pentavalent arsenic (also called As(V), As(+5), and arsenate) and trivalent arsenic (also called As(III), As(+3), and arsenite). In well water, arsenic may be pentavalent, trivalent, or a combination of both. Special sampling procedures are needed for a lab to determine what type and how much of each type of arsenic is in the water. Check with the labs in your area to see if they can provide this type of service.

Reverse osmosis (RO) water treatment systems do not remove trivalent arsenic from water very well. RO systems are very effective at removing pentavalent arsenic. A free chlorine residual will rapidly convert trivalent arsenic to pentavalent arsenic. Other water treatment chemicals such as ozone and potassium permanganate will also change trivalent arsenic to pentavalent arsenic. A combined chlorine residual (also called chloramine) may not convert all the trivalent arsenic. If you get your water from a public water utility, contact the utility to find out if free chlorine or combined chlorine is used in the water system.

The FreshStream systems are designed to remove pentavalent arsenic. They will not convert trivalent arsenic to pentavalent arsenic. The system was tested in a lab. Under testing conditions, the systems typically reduced 0.30 mg/L (ppm) pentavalent arsenic to 0.010 mg/L (ppm) (the USEPA standard for drinking water) or less. The performance of the system may be different at your installation. Have the water tested for arsenic to check whether the system is working properly.

The RO component in these systems must be replaced every 12 months or when the test above rises above 10ppm to ensure the system will continue to remove pentavalent arsenic. The component identification and locations where you can purchase the component are listed in the installation/operation manual.

Appendix A: Theory of Operation
Flow Schematic Figure A-1

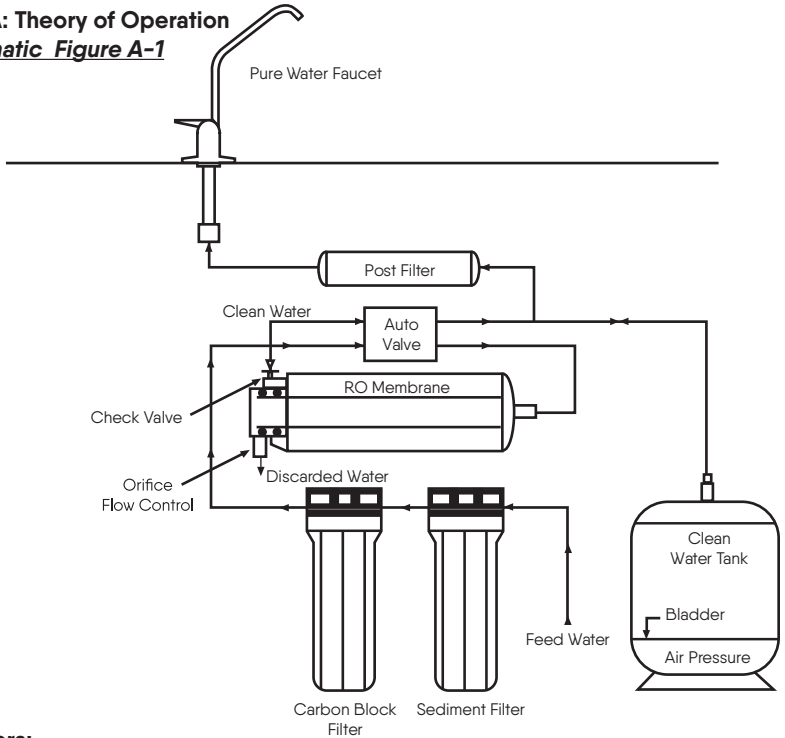

A.1 Pre-Filters:

The pre-filters have two purposes, one is to clean the water for better consumption, and the second is to prevent the RO membrane from being fouled. The first stage filter removes sediment materials such as sand, rust, pipe scale, and dirt. It is made of a spun polypropylene material that will take out particles down to 5 -microns.

The water then goes to the carbon block filter, which is important for two reasons. First, it takes out 90% of the chlorine in the water thereby protecting the RO membrane from damage by the presence of chlorine. It also removes the taste of the chlorine, as well as other tastes and odors that affect the drinking water changing the flavor of tea, coffee or other mixed drinks. (The carbon accomplishes this by adsorption on its surface). This is a chemical/mechanical process unique to carbon that has been activated -made to have high surface area. The second reason is that the carbon block also takes out VOCs (volatile organic chemicals) which are contaminants from industrial pollution. Claims for reduction of chlorine and VOCs have not yet been certified by the Water Quality Association.

A.2 The Reverse Osmosis Membrane:

This is the heart of the Machine, and the great protector. The membrane is a replication of human or animal stomach tissue, which permits the water molecule to pass through, but holds the dissolved molecules back. This occurs naturally by osmotic pressure developed because of the content of dissolved solids. To make this happen with the RO membrane we reverse the osmotic pressure by applying pressure to the water (reversing the process of

generating pressure) to push the water molecules through the membrane, but keeping most of the dissolved solid molecules behind.

The reverse osmosis technology will, on average, reject 93% of the total dissolved solids in the incoming water. Over time, the RO membrane will foul with a very thin layer of materials and the efficiency will drop, so that the TDS content of the clean water will rise. When it rises to greater than 30% of the inlet TDS value, it is an indicator that the RO membrane should be replaced. This occurs every 3-4 years. (See section 4)

About 4 gallons of water is discarded for every gallon of pure water made. In Figure A- 1, the discard is shown with a flow control orifice at the outlet of the RO stage. This is designed to hold back the discard water to the above ratio, and maintain pressure on the water in the membrane. For a 50-gallon per day membrane, approximately 520 milliliters per minute of water are discarded. Note there is a check valve on the clean water outlet from the RO. The purpose is to prevent backflow of water to the membrane from the tank or faucet or because of autovalve failure. In the average household, about 3 gallons of drinking water are used a day.

A.3 Auto Control:

As water is produced the pressure in the storage tank increases. To stop production of water when the tank is full, an auto control valve is used in the system, as shown in Figure A-1. The pressure in the tank is set nominally to be 2/3 of the incoming line pressure. When this ratio is reached the autovalve will close. Normal U.S. city water pressure is 60-psi, therefore the tank pressure, when water flow stops, is 40-psi.

The purified water goes to the tank where it is stored at pressure as described above. The tank has a bladder in it, and on one side is air at 6-psi, initially. The initial volume of the storage tank is 4.0 gallons. As the water fills the tank, it pushes against the bladder, and raises the pressure as it takes space in the tank. When the pressure increases to 40-psi, water flow stops. The net amount of water in the tank when full, less the space taken by the air at 40-psi is approximately 2.5 gallons. When water is drawn through the clean water faucet on the sink, the water flows through the final activated carbon post filter, which polishes the water by taking out any staleness which has set in. When water is supplied to the refrigerator, the line should be therefore taken after the post filter.

When the raw water pressure available is 40-psi or less, the RO membrane will not operate efficiently or produce water at a reasonable rate. To overcome this use an add-on booster pump set – Vertex p/n PMPA-8014

Notes

Water Disinfection with chlorine bleach (5.25%)

<u>Quantity</u>	<u>Clean Water</u>	<u>Cloudy Water</u>
1 quart	2 drops	4 drops
1 gallon	8 drops	16 drops
5 gallons	1/2 tsp.	1 tsp.



Kenai • 8150 N. Lehigh Ave, Morton Grove, IL 60053 • kenai@chargerwater.com
www.kenaiwater.com • Kenai is a trademark of Charger Water Treatment Products. 2020